



smicon

improve the process

improve the future



FILTERING



SP300

Since its introduction in 1998 the SP300 screw compression filter has proven its worth. This machine is ideally suited for the controlled dewatering and separation of various liquid waste and residue flows from industrial, organic and agricultural processes. With the help of an internal screw and filter, the liquid effluent is transported through the SP300. The resulting dewatered product which can in many cases be stacked, exits the machine via the delivery chamber.



- ▶ **The back pressure in the delivery chamber can be adjusted with great accuracy**
- ▶ **Works already with a very low dry matter content in the influent stream**
- ▶ **No pressure build-up on the filter**

INPUT
RESIDUE, FRESH
PRODUCE AND
PACKAGED
FOODSTUFFS



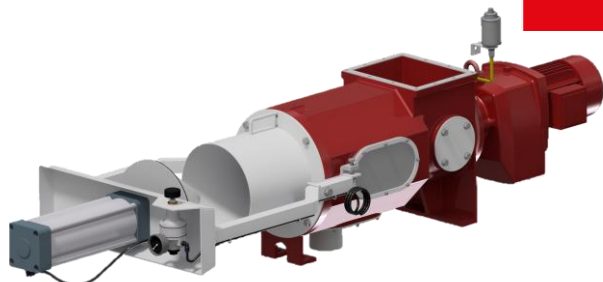

OUTPUT
EFFLUENT AND
FIBRES



SP300

TECHNICAL DATA

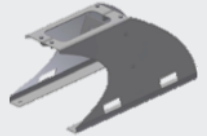
Dimensions	
Machine general	2446 x 717 x 491 mm (LxWxH)
Infeed	285 x 220 mm (LxW)
Outfeed effluent	Ø 101,6 mm
Outfeed fibres	Ø 300 mm
Transport dimensions	2500 x 800 x 500 mm (LxWxH)
Transport volume	0,715 m ³
Clearance area	3021 x 1970 x 1342 mm (LxWxH)
Filter surface	0,38 m ²
Filter mesh size (gap width)	150, 250, 500, 750, 1000 µm
Weight	
Weight	370 kg
Floor load per feet	1,85 kN static (see □)
Transport weight	400 kg
Drive	
Power	2,2 kW
RPM shaft	24 RPM
Product information	
Capacity	0-100 m ³ /hour
Maximum ball passage	Ø 50 mm
Product temperature	1-70 °C
Dry matter	1-30 %
Other specifications	
A-weighted sound pressure level	<74 dB
C-weighted instantaneous sound pressure	<130 dB
Technical data is specified according to the machine without accessories	

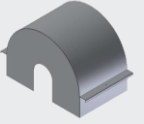
Accessories	
Frame 1 	Frame 2 
Infeed funnel 	Cover 
Control panel 